



SEMI-AUTOMATIC MODEL B-600 VOLUMETRIC AUGER FILLING



For Dispensing Powders, Granules, and Liquids

The Model **B-600** Auger Filling Machine is the latest development from ALL-FILL. The innovative design and PLC-based controls make the Model B-600 an affordable, reliable, auger filler with the same rugged construction and dependable service which ALL-FILL is renowned for.

THE CONTROLS ARE THE DIFFERENCE

The B-600 features Allen-Bradley PLC-based controls which meet your individual application. The controls have special enhanced features, which are described on the itemized chart on the back of this brochure.

MECHANICAL/PHYSICAL CHARACTERISTICS

- High Performance Clutch/Brake Control with Encoder and Coast Compensation
- Unique Versatility - For Filling Powders, Granules, and Liquids
- Universal Filling Accessories
- 3-Speed Fill Motor Drive System
- Rugged Head Casting and Stable Cast Base
- Quick and Easy Hopper and Filling Accessory Removal
- Fully Enclosed Agitation Drive
- One-Piece Stainless Steel Head Cover and Stainless Steel Contact Parts
- Optional Portable Frame With Jack Assembly
- Funnel Removal Detection
- Same dependable ALL-FILL service and support

Dimensions & Specifications

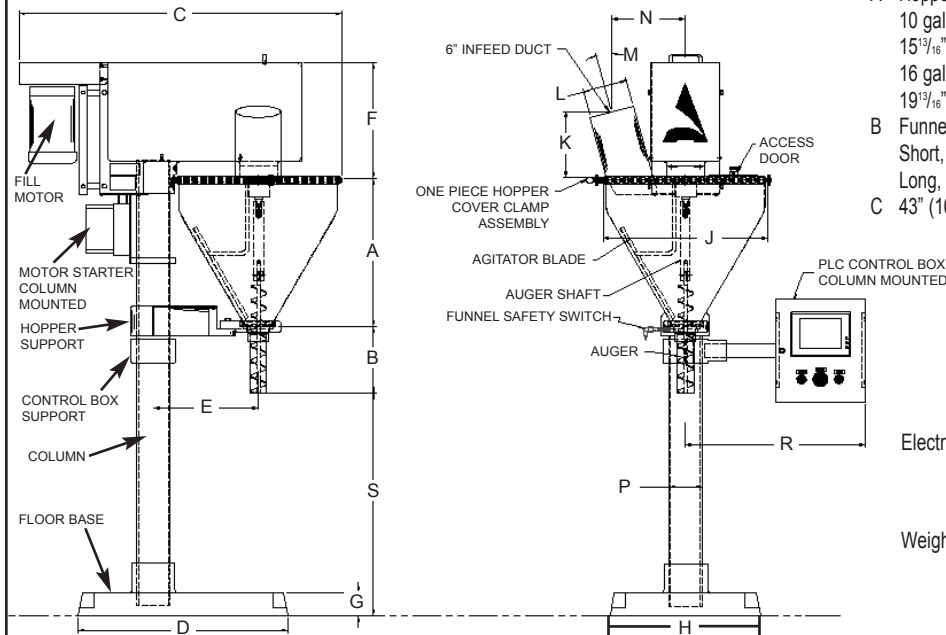

- | | | | |
|---|---|---|---|
| A | Hoppers | D | 28" (711.2 mm) |
| | 10 gal. (37.8L): | E | 14" (356 mm) |
| | 15 ⁹ / ₁₆ " (401.63 mm) | F | 15 ¹ / ₂ " (393.7 mm) |
| | 16 gal. (60.5L): | G | 3" (76 mm) |
| | 19 ⁹ / ₁₆ " (503.24 mm) | H | 20" (508 mm) |
| B | Funnels | J | 22" dia. (559 mm) |
| | Short, No. 4-52: 5 ⁹ / ₁₆ " (141.29 mm) | K | 8 ⁷ / ₁₆ " (225.42 mm) |
| | Long, No. 4-52: 12 ⁹ / ₁₆ " (319.09 mm) | L | 6" (152.40 mm) |
| C | 43" (1092 mm) | M | 15° |
| | | N | 9 ²⁷ / ₃₂ " (250.03 mm) |
| | | P | 4 ¹ / ₂ " (114 mm) |
| | | R | 24" (609.6 mm) |
| | | S | By Application |

Electrical Motors : 208/230/460V, 60 Hz., 3-Phase
 Controls: 120V, 60 Hz., Single Phase
 Other ratings upon request

Weight 375 lb.
 Crated Weight: 500 lb.
 Crate Size: 48" H x 48" L x 96" W

Dimensions listed as reference only. Not to be used for layout or construction.

CONTROLS

CONTROL FEATURES	B-600
Programmable Logic Controller	Allen Bradley Micrologix 1500
Operator Interface	Maple 520
Controls Enclosure	Nema 12 (Dust Tight)
Recipe Setup Program Capability	50 Programs
Clutch/Brake Coast Compensation	Yes
Alphanumeric Product Code	Yes
Programmable Agitation Mode	Yes
Alarm Function Indicators/Error Messages	Yes
Status Messages	Yes
Hopper Level Monitored and Displayed	Yes
Maintenance Screen(s) for Testing Purposes	Yes
Cutoff Device	Yes
Storage of Accessory Information for Each Product	Yes
Production Counter Display	Yes
Production Containers Per Minute Display	Yes
End of Fill Signal	Yes
Product Infeed Control	Yes
Weight Feedback from in-motion Checkweigher	Yes
Recycle	Yes
Remotely Mounted Panel	Yes
Auger Jam Protection	Yes
Manual Calibration	Yes
Off-Line Scale Feedback	Yes
Special Features Capability	Yes

FILLING ACCESSORIES

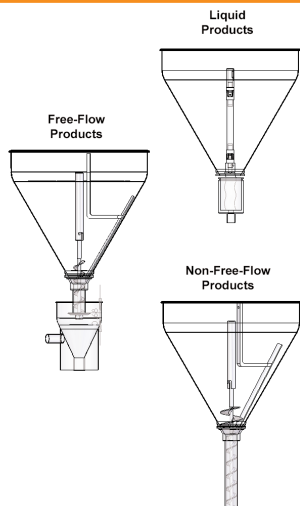

All-Fill: For All Your Filling Needs.

All-Fill, Inc. designs, manufactures, services, and supports a complete line of machinery for powder and liquid filling. Complementary equipment includes feeding and conveying of dry products for the food, pharmaceutical, and chemical industries, as well as high-speed checkweighing equipment sold under the Alpha Checkweighers brand.

418 Creamery Way
Exton, PA 19341 USA
1-866-ALL-FILL
Fax: (610) 524-7346
www.all-fill.com

