



# LOW COST SEMI-AUTOMATIC AUGER FILLING MACHINE

MODEL B-350e



## For Dispensing Powders, Granules, and Liquids

The Model B-350e Auger Filling Machine is the latest development from ALL-FILL. The innovative design and improved PLC-based controls make it an affordable, reliable, auger filler with the same rugged construction and dependable service which ALL-FILL is renowned for.

The Model B-350e is ALL-FILL's answer to your "back to simplicity" filling need. Low cost, quick delivery, and extremely easy to operate - the Model B-350e can provide you with automated filling at a "bare-bones" expenditure.

### CHARACTERISTICS

- "Off-the-Shelf" Integral PLC Control and Operator Interface
- High Performance Clutch/Brake Control with Encoder and Coast Compensation
- Universal Filling Accessories
- 3-Speed Fill Motor Drive System
- Rugged Head Casting and Sturdy Base
- Quick and Easy Hopper and Filling Accessory Removal
- Fully Enclosed Agitation Drive
- One-Piece Stainless Steel Head Cover and Stainless Steel Contact Parts
- Optional Portable Frame With Jack Assembly
- Funnel Removal Detection

### WORLD CLASS SERVICE AND SUPPORT.

All-Fill uses quality off-the-shelf components so spares are readily available and costs are reduced. All programming is written and supported by in-house engineers.

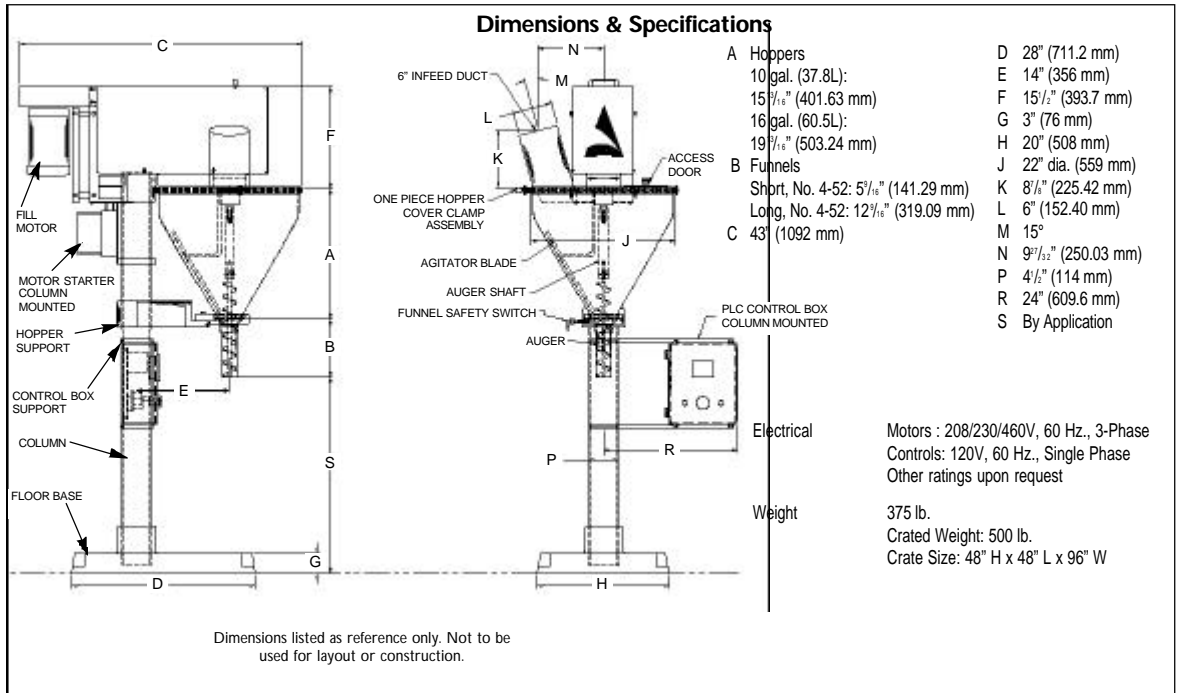

## CONTROLS

- "Off-The-Shelf" Integral PLC Control and Operator Interface
- Direct Entry of Auger Revolutions
- Agitation Mode (Continuous, With Fill, Off)
- Recycle Mode With Adjustable Dwell Time
- Hopper Empty Mode
- 5 Product Setup Capacity
- Coast Compensation
- Auger Jam Protection
- End of Fill/Hanshake Signal
- Error/Messages Status

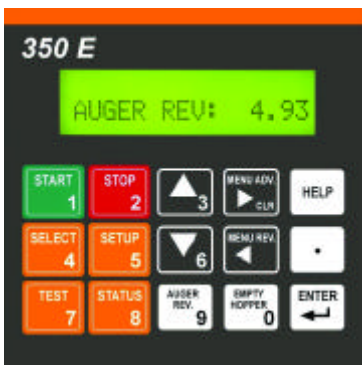

### Filling Accessories

Filling accessories are available in a wide variety of types and sizes to handle nearly any powder, paste, or liquid product. Fill weights from under 1 gram to 50 kg and beyond can be addressed.

Non-free-flow powders (talcum, spices, ground coffee, flour-based products, Ag-chems, toner) and free-flow products (salt, drink mixes, detergents, pool chemicals) can all be filled by All-Fill Auger Fillers. Heavy pastes and thin liquids can also be handled.

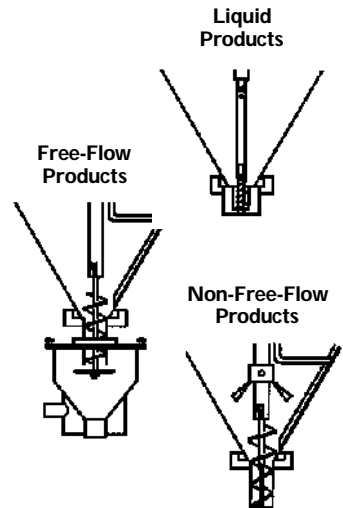

### All-Fill: For All Your Filling Needs.

All-Fill, Inc. designs, manufactures, services, and supports a complete line of machinery for powder and liquid filling. Complementary equipment includes feeding and conveying of dry products for the food, pharmaceutical, and chemical industries, as well as high-speed checkweighing equipment sold under the Alpha Checkweighers brand.

418 Creamery Way  
Exton, PA 19341 USA  
1-866-ALL-FILL  
Fax: (610) 524-7346

[www.all-fill.com](http://www.all-fill.com)

